

ARTÍCULO

REFERENCIA CT25 - CAJA EMPALMES 300x200x60 CON TORNILLOS

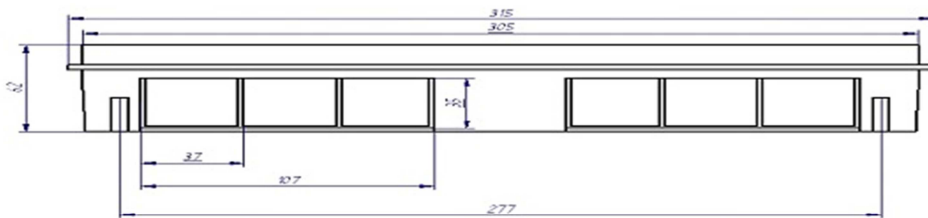
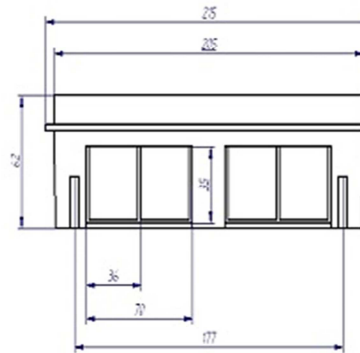
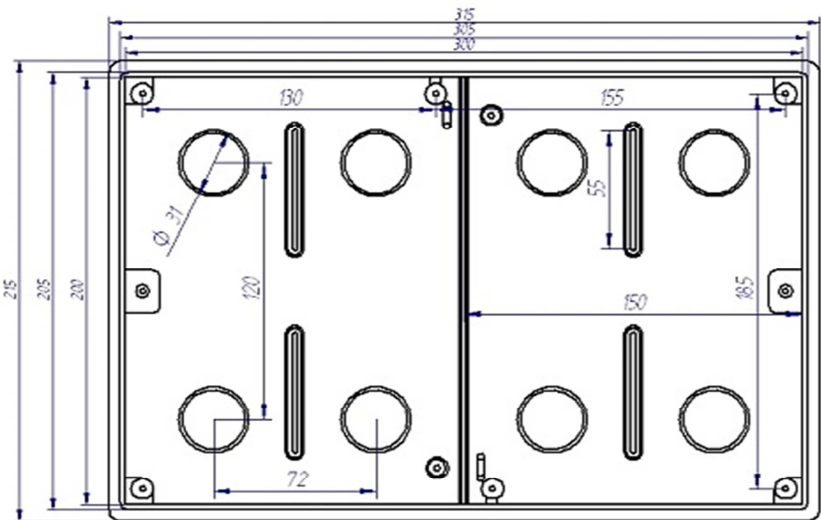

DATOS TÉCNICOS

Denominación: Caja de empalmes y derivación con tornillo.

Medidas: 300x200x60mm.

Fabricado en material termoplástico libre de halógenos

Color caja : Negro

Color tapa: Blanco

Peso neto: 0,504 Kg.

Código EAN

CT25



MARCAS Y CERTIFICACIONES

